

AL9100 SERIES GRP Quartz Evo Bollard

Abacus[®]
Leaders in Lighting

Redefining the benchmark for bollard performance

This next generation of LED bollard takes the existing tried and tested design of the LED Quartz and combines it with the latest cutting edge optical and GRP technologies.

Our Glass-fibre Reinforced Polyester (GRP) range provides a passively safe, non-conductive alternative to concrete and steel.

With power consumption reduced by almost 50% against the original product, significant performance gains and market leading bollard spacings greater than any other product on the market, the Quartz Evo redefines the benchmark of modern bollard lighting.

Key Features

- Non-conductive GRP material
- Revolutionary low glare optic design giving unrivalled uniformity and bollard spacing
- Symmetrical and asymmetrical options to suit all requirements
- Wider door width for ease of installation and maintenance
- Quarter turn closing mechanism for ease of use
- Vandal resistant, IP66 flush door and fixings
- Flange plated and root mounted options available
- 3 hour emergency battery backup option available



AL9100 SERIES GRP Quartz Evo Bollard

Abacus®

Leaders in Lighting

Technical Specifications

Technical specification	Asymmetric	Symmetric
Power (W)	12.8W	16.2W
Luminous Flux (net)	1590 lm	2050 lm
Weight	Head: 3.6kg Flange base: 5.6kg Root base: 6kg	
Colour Temperature	4000K (3000K optional*)	
Colour Rendering Index (CRI)	Ra 70	
Colours	Jet Black: RAL9005 (options available*)	

Spacings and Example Levels

Beam Type	Spacing (m)	Ave	Min	Unif
Asymmetric	10	21.1	10.8	0.51
	12	17.6	5.9	0.34
	15	14.1	2.5	0.18
	18	11.8	1.2	0.10
Symmetric	20	10.2	0.8	0.08
	10	17.4	9.6	0.55
	12	14.5	6	0.41
	15	11.6	2.8	0.24
	20	8.7	1.0	0.11

This information is based on a straight, 3m wide path with no obstructions and bollards 700mm back to center

*Please contact Abacus for further details on non-standard options, MOQs may apply.

Market Competition

Distance	Quantity of bollards needed	
	Quartz EVO	Market Competition
200m	14	17
300m	20	25
500m	34	42

Quartz EVO bollard:

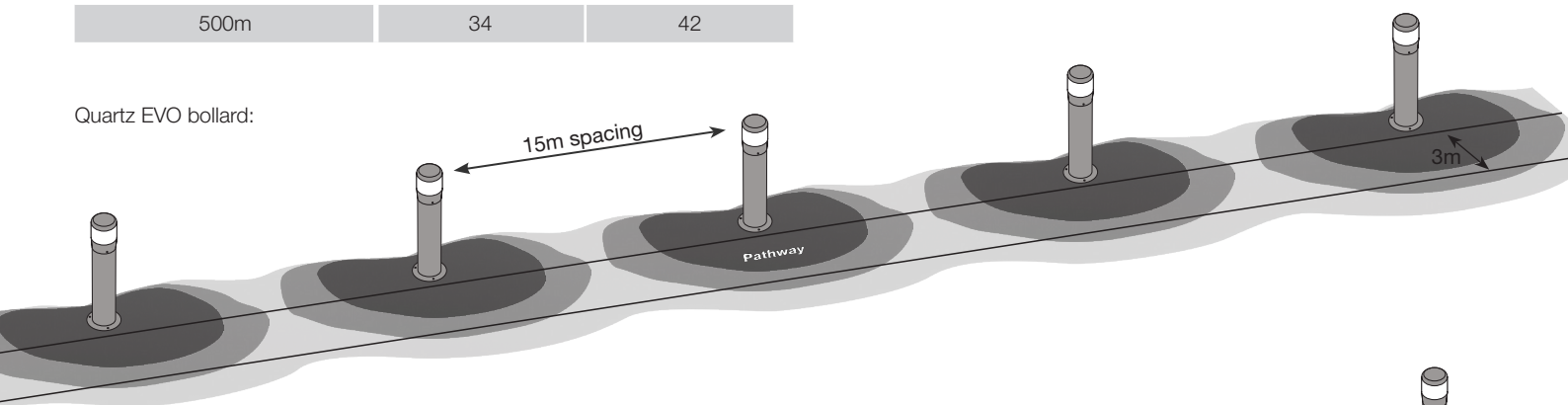

Alternative market competition:

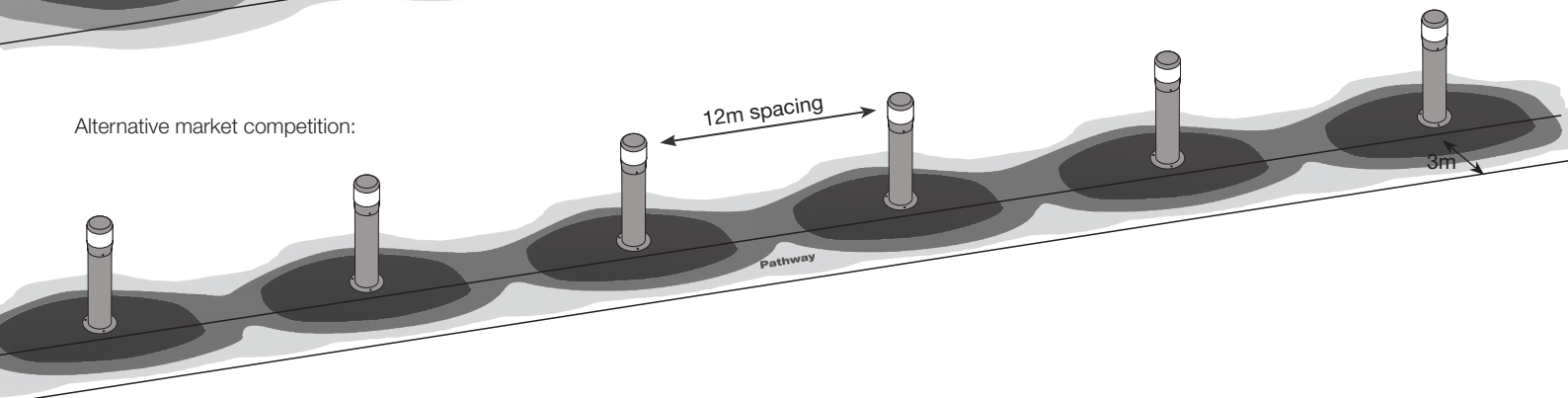

AL9100 SERIES GRP Quartz Evo Bollard

Abacus®

Leaders in Lighting

Product Code Selection

Beam Type & Power	Colour Temp (CCT)	Mounting	Colour	Driver option	Emergency	Control
AL910 1 Symmetric - 15W	4 = 4000K	F = Flange Mounted	Jet B lack: RAL9005	A = 1-10	E = Fitted	X = Not fitted
AL910 2 Asymmetric - 12W	3 = 3000K*	R = Root Mounted*	S ilver: RAL9006* Anthracite G rey: RAL7016*	B = DALI	X = Not fitted	Options TBC

Example Product Selection:

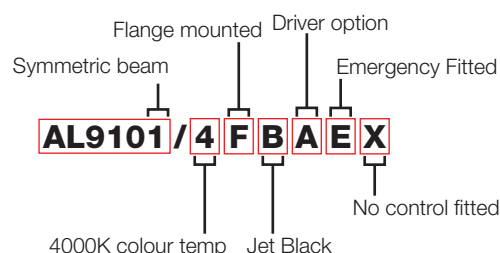
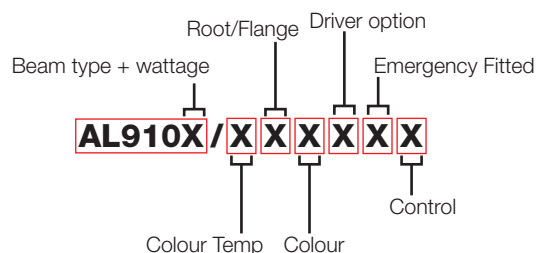

*Please contact Abacus for further details on non-standard options, MOQs may apply.

Dimensions

Root mounted:

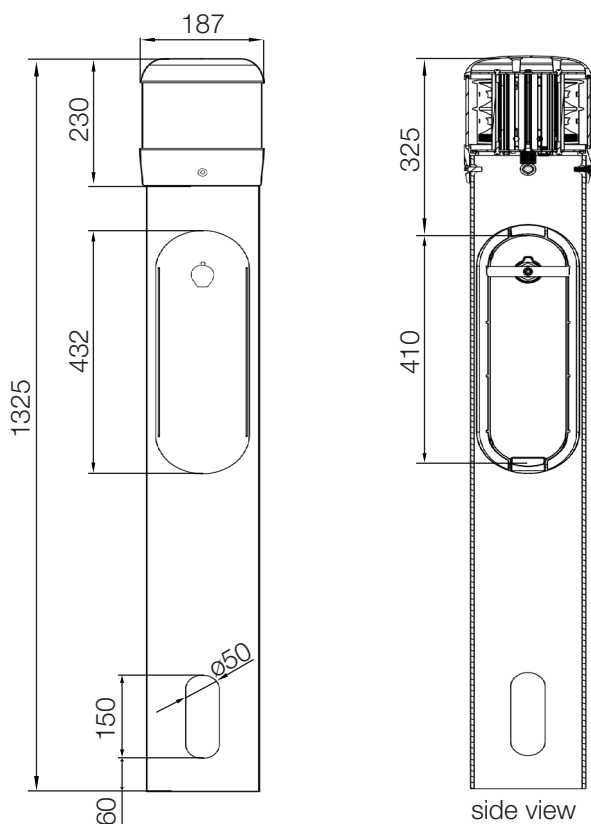

Flange plate:

